



Connecting Conveyor

CATALOG



Table of Content

Automatic Sucking Loader	1
Automatic PCB Cleaning Machine (Smart Type)	2
Automatic Loader / Unloader	3
Automatic Vacuum Loader / Unloader	4
Automatic Loader / Unloader	5
Automatic PCB Cleaning Machine	6
NG Buffer	7
Multi-Function Buffer (Smart Type)	8
NG Buffer	9
Multi-Functional Buffer	10
Conveyor	11
Conveyor (Smart Type)	12
Automatic Translational Conveyor	13
Automatic Translational Conveyor	14
Automatic Inverting Machine	15
Automatic Unloader (Dual Track)	16
Unloaded NG/OK	17
Automatic Unloader (Dual Rail for NG / OK)	18
Automatic Aisle Conveyor	19

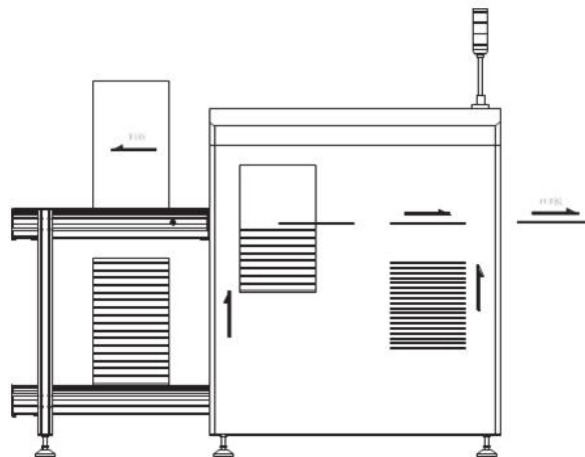

Automatic Sucking Loader

Features:

This equipment can be used for sucking boards pushing boards.

1. Adopt Panasonic PLC programmable control system, touch screen operation, easy to understand.
2. Two modes: magazine Loader and Vacuum Suction Loader.
3. The spacing and speed can be set freely.
4. Adopts Japanese SMC cylinder, push board stable and reliable.
5. Automatic fault detection, touch screen display failure IO point functions shown in touch screen, simple and clear.
6. Adopt imported wire bar platform, smooth, stable, wearproof.
7. Adopt German tow-chain cable, resistant to folding and wear.
8. Compatible SMEWA interface.

Technical Parameters:

1. Transmission height: 900 ± 30mm
2. Platform substrate storage: H200mm or 300 sheets/0.6mm
3. Indexing pitch: 10.20.30.40 mm or customer specified
4. Suction board board board time: ≥ 6 seconds
5. Number of magazines: upper, bottom
6. Track fixed mode: front fixed or customer specified
7. Transmission direction: From left to right or from right to left
8. Power supply: 230V AC; Single phase maximum 250 Volt

Options:

1. Capacity of magazine
2. The size of the sucker
3. Automatic width adjustment function
4. Increase the storage capacity of the sucker platform
5. Other can be customized

Model	PCB Size (L x W ; mm)	Magazine Size (L x W x H ; mm)	Magazine Dimensions (L x W x H ; mm)	Machine Weight (Kg)
MT-250VL	50*50 – 330*250 (mm)	335*320*563mm	1600*980*1600mm	220
MT-330VL	50*50 – 445*330 (mm)	460*400*563mm	1850*1050*1600mm	260
MT-390VL	50*50 – 530*390 (mm)	535*460*563mm	2050*1150*1600mm	300
MT-460VL	50*50 – 530*460 (mm)	535*530*563mm	2050*1250*1600mm	320



Automatic PCB Cleaning Machine (Smart Type)

Features:

This equipment is design for SMT unmanned workshop. It is used for cleaning the surface and eliminating the static of PCB board which comes out from laser marking machine or will be placed before stencil printer.

1. Independent innovation patent design(patent: 2017 SR471774), No.1 in the industry, can increase production capacity by 12.5 % per day.
2. Adopt Panasonic PLC programmable control system, touch screen operation, easy to understand.
3. The internal design of the machine has Bluetooth WiFi, which can achieve APP remote control machine station.
4. PLC has network interface, which can interface with MES system.
5. Two-piece imported sticky dust roller, automatic lifting work design.
6. Unique design brush device, effectively clean large dust, and protect the abrasion of the dust roller.
7. For inlet and outlet, equipped with an electrostatic canceller, which can efficiently remove the remaining electrostatic of PCB.
8. Stepping motor for transmission, stable and convenient.
9. Unique modular structure design, tricolor warning light indicating working states.
10. Automatic fault detection, failure IO point shown in the touch screen, simple and clear.
11. Adopt Panasonic SENSOR for inlet, outlet and limit, accurate and stable.
12. Central support is provided in the middle, which could prevent the large PCB from deformation.
13. Full automatic width adjustment design, using the imported ball screw, accurate, smooth and stable.
14. Touch screen with a variety of working mode choices, steady and stable.
15. Electrostatic real-time monitoring system is installed inside the machine to ensure the reliability of electrostatic removal.
16. SMEMA interface.

Technical Parameters:

1. Transmission height: 900 ± 30mm
2. PCB thickness: 0.6-5 mm(or customer specified)
3. Transmission speed: 0.5-20M / min
4. Brush number: 1 PCs
5. Dust roller quantity: 2 PCs
6. Dust paper quantity: 1 PCs
7. Electrostatic canceller: 2pcs
8. Air pressure and air consumption: 4-6 bar; Up to 10 litres per minute
9. Belt Type: Imported wearproof flat belt
10. Transmission direction: From left to right or from right to left
11. Power supply: 230V AC; Single phase maximum 250 Volt
12. Track fixed mode: pre-fixed or customer specified

Options:

1. Both sides clean at the same time
2. Other can be customized to customer requirements

Model	PCB Size (L x W ; mm)	Magazine Dimensions (L x W x H ; mm)	Machine Weight (Kg)
MT-250CW	100*50 - 350*250mm	550*700*1600mm	120
MT-350CW	100*50 - 450*350mm	550*800*1600mm	140
MT-450CW	100*50 - 500*450mm	600*900*1600mm	170

CONNECTING CONVEYOR CATALOG

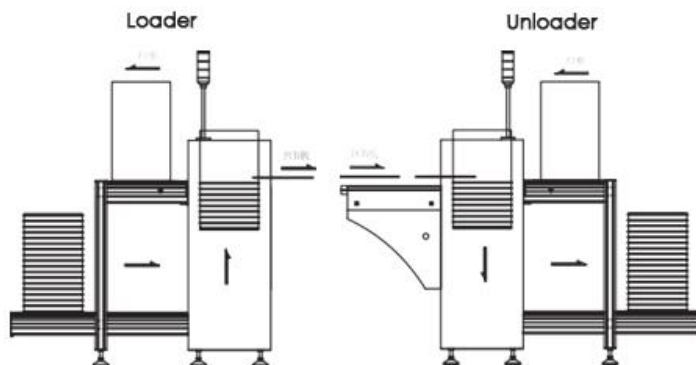

Automatic Loader / Unloader

Features:

This equipment is suitable for feeding boards and receiving boards in SMT production line.

1. Panasonic PLC programmable control system, touch screen operation, easy to understand.
2. Unique modular structure design, tricolor warning light indicating working states.
3. Multiple points clamping design to ensure the homogeneity of each change frame.
4. Adopt Japanese SMC cylinder to push boards, stable and reliable.
5. Automatic fault detection, failure IO point showed in the screen, simple and clear.
6. Use imported wire bar platform, smooth, stable and wearproof.
7. Adopt German tow-chain cable, resistant to folding and wear.
8. Compatible SMEMA interface.

Technical Parameters:

1. Transmission height: 900 ± 30mm
2. Indexing pitch: 10.20.30.40 mm or customer specified
3. Numbers of magazine: up 1; bottom 1
4. Magazine replacement time: about 30 seconds or customer specified
5. Track fixed mode: front fixed or customer specified
6. Transmission direction: From left to right or from right to left
7. Power supply: 230V AC; Single phase maximum 250 Volt
8. Air pressure and air consumption: 4-6 bar, up to 10 litres per minute

Options:

1. Capacity of magazine
2. All safety protection
3. Automatic width adjustment function
4. Other can be customized

	Model	PCB Size (L x W ; mm)	Magazine Size (L x W x H ; mm)	Magazine Dimensions (L x W x H ; mm)	Machine Weight (Kg)
Loader	MT-250LD	50*50 - 330*250mm	355*320*563mm	1300*756*1600mm	140
	MT-330LD	50*50 - 445*330mm	460*400*563mm	1600*845*1600mm	170
	MT-390LD	50*50 - 530*390mm	535*460*563mm	1800*909*1600mm	210
	MT-460LD	50*50 - 530*460mm	535*530*563mm	1800*970*1600mm	240
Unloader	MT-250UL	50*50 - 330*250mm	355*320*563mm	1750*756*1600mm	160
	MT-330UL	50*50 - 445*330mm	460*400*563mm	2000*845*1600mm	190
	MT-390UL	50*50 - 530*390mm	535*460*563mm	2200*909*1600mm	230
	MT-460UL	50*50 - 530*460mm	535*530*563mm	2200*970*1600mm	260

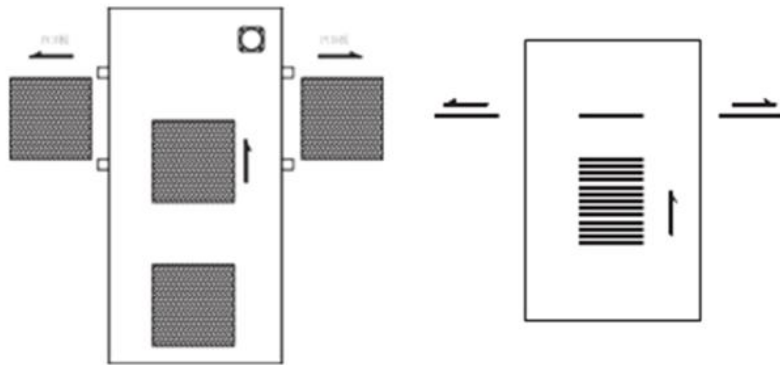

Automatic Vacuum Loader / Unloader

Specifications:

This equipment is suitable for sucking boards.

1. Adopt Panasonic PLC programmable control system, touch screen operation, easy to understand.
2. Vacuum sucker can be moved freely, easy to adjust and wide range.
3. Use stepping motor to move the sucker, smooth and stable.
4. Full-closed design, safe and reliable.
5. Automatic fault detection, touch screen display failure IO point function, simple and clear.
6. Use imported wire bar platform, smooth, stable and wearproof.
7. Adopt German ball screw, resistant to folding and wear.
8. SMEMA interface.

Technical Parameters:

1. Transmission height: 900 ± 30mm
2. Platform substrate storage: H200mm or 300 sheets/0.6 mm
3. Suction board time: ≥ 6 seconds
4. Track fixed mode: front fixed or customized
5. Transmission direction: From left to right or from right to left
6. Power supply: 230V AC; Single phase maximum 250 Volt
7. Air pressure and air consumption: 4-6 bar, up to 10 litres per minute

Options:

1. The size of the sucker
2. Automatic width adjustment function
3. Increased storage capacity of sucker platforms
4. Others can be customized

	Model	PCB Size (L x W ; mm)	Magazine Dimensions (L x W x H ; mm)	Machine Weight (Kg)
Automatic Vacuum Loader	MT-250SM	50*50 – 350*250mm	500*980*1600mm	110
	MT-350SM	50*50 – 450*350mm	500*1140*1600mm	140
	MT-450SM	50*50 - 500*450mm	600*1280*1600mm	170
Automatic Vacuum Unloader	MT-250SD	50*50 – 350*250mm	500*980*1600mm	110
	MT-350SD	50*50 – 450*350mm	550*1140*1600mm	140

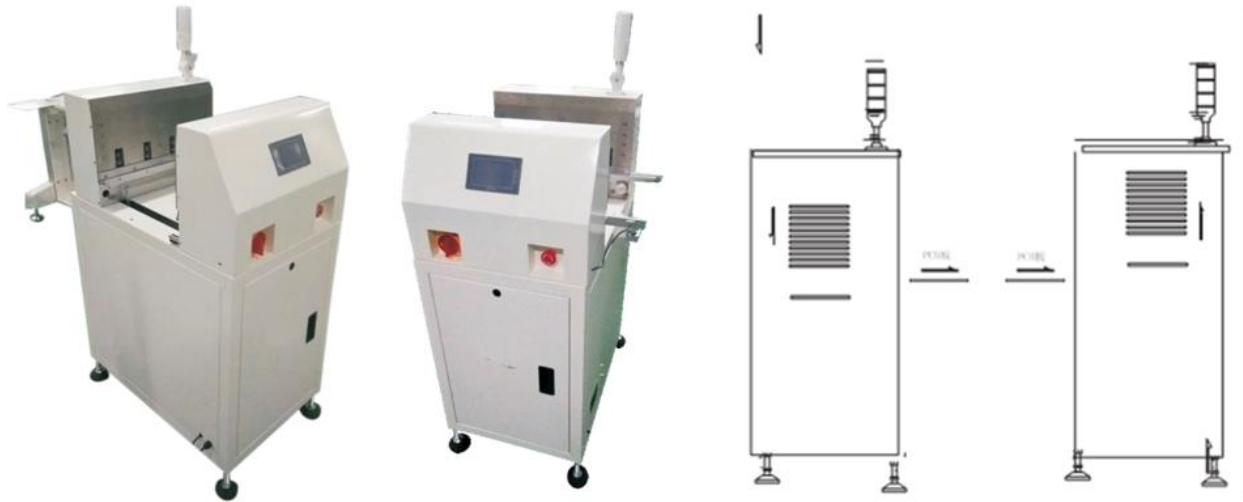

Automatic Loader / Unloader

Features:

This equipment is used for loading and unloading of PCB boards in SMT production line

1. Panasonic PLC programmable control system, touch screen operation, easy to understand.
2. Unique modular structure design, tricolor warning light indicating working states.
3. No interference, stop and add boards function.
4. Automatic positioning design, no need to adjust.
5. Automatic fault detection, touch screen display failure IO point function, simple and clear.
6. Large storage of PCB.
7. Warning function for fewer boards, which means need to add more boards.
8. Compatible SMEMA interface.

Technical Parameters:

1. Transmission height: 900 ± 30mm
2. Cycle time: ≥ 4 seconds
3. PCB substrate storage: H200mm or 300/0.6 mm thick plate
4. PCB substrate thickness: ≥ 0.6 mm
5. Track fixed mode: front fixed or customer specified
6. Transmission direction: From left to right or from right to left
7. Power supply: 230V AC; Single phase maximum 250 Volt
8. Air pressure and air consumption: 4-6 bar, up to 10 litres per minute

Options:

	Model	PCB Size (L x W ; mm)	Magazine Dimensions (L x W x H ; mm)	Machine Weight (Kg)
Fold up Machine	MT-250PM	50*50 – 330*250mm	600*760*1600mm	140
	MT-350PM	50*50 – 450*350mm	600*860*1600mm	170
	MT-460PM	50*50 – 530*460mm	700*980*1600mm	210
Fold Down Machine	MT-250BM	50*50 – 330*250mm	600*760*1600mm	140
	MT-350BM	50*50 – 450*350mm	600*860*1600mm	170

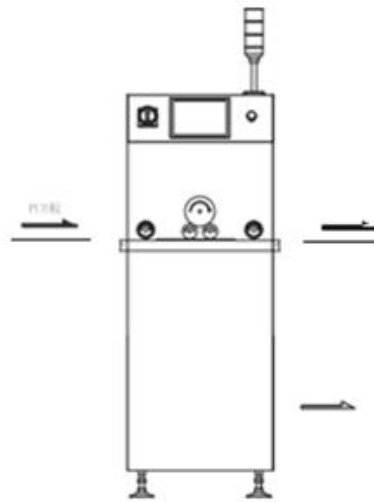

Automatic PCB Cleaning Machine

Specifications:

This equipment is used for cleaning the surface and eliminating the static of PCB boards which come out from laser marking machine or will be placed before stencil printer.

1. Adopt Panasonic PLC programmable control system, touch screen operation, easy to understand.
2. Two pieces of imported sticky dust roller, automatic lifting work design.
3. Unique design brush device, effectively clean large dust, and protect the abrasion of the dust roller.
4. For inlet and outlet, equipped with an electrostatic canceller, which can efficiently remove the remaining electrostatic of PCB.
5. The transmission is driven by stepping motor, accurate and stable.
6. Central support is provided in the middle, which could prevent the large PCB from deformation.
7. Modular design of the whole machine, easy to maintain.
8. SMTA interface.

Technical Parameters:

1. Transmission height: 900 ± 30mm
2. PCB thickness: 0.6-5 mm(or customerized)
3. Transmission speed: 0.5-20M / min
4. Amount of brush : 1 PCs
5. Amount Dust roller : 2 PCs
6. Amount Dust paper: 1 PCs
7. Electrostatic canceller: 2pcs
8. Air pressure and air consumption: 4-6 bar; Up to 10 litres per minute
9. Belt type: imported wearproof flat belt
10. Transmission direction: From left to right or from right to left
11. Power supply: 230V AC; Single phase maximum 250 Volt
12. Track fixed mode: pre-fixed or customer specified

Options:

1. Automatically adjust width
2. Electrostatic real-time monitoring
3. Both sides clean at the same time
4. Other can be customized

Model	PCB Size (L x W ; mm)	Magazine Dimensions (L x W x H ; mm)	Machine Weight (Kg)
MT-250CLB	100*50 - 350*250mm	550*700*1600mm	120
MT-350CLB	100*50 - 450*350mm	550*800*1600mm	140
MT-450CLB	100*50 - 500*450mm	600*900*1600mm	170



NG Buffer

Features:

This equipment is used for separating and collecting NG boards all boards after testing equipment.

1. Adopt Panasonic PLC programmable control system, touch screen operation, easy to understand.
2. Multi-segment design, stable and easy to use.
3. Can store 10 NG boards.
4. Adopt Panasonic SENSOR for inlet, outlet and stop, accurate and reliable.
5. Equipped with a variety of alarm sounds.
6. Stepping motor is used to lift platform, reliable and stable.
7. SMEMA interface.

Technical Parameters:

1. Transmission height: 900 ± 30mm
2. Transmission speed: 0.5 to 20M/MIN
3. Intersection: 15mm(or customer specified)
4. Track fixed mode: 1 track fixed(or customer specified)
5. Belt Type: Imported wearproof flat belt
6. Transmission direction: From left to right or from right to left
7. Power supply: 230V AC; Single phase maximum 250 Volt

Options:

1. Touch screen operation interface
2. Capacity of PCB
3. Machine size
4. Other can be customized

	Model	PCB Size (L x W ; mm)	Magazine Dimensions (L x W x H ; mm)	Machine Weight (Kg)
Single Rail	MT-050BU	50*50 – 500*350mm	500*740*900mm	80
	MT-100BU	50*50 – 500*300mm	1000*740*900mm	110
Dual Rails	MT-050DU	50*50 – 500*350mm*2	500*1400*900mm	120
	MT-100DU	50*50 – 500*300mm*2	1000*1400*900mm	150



Multi-Function Buffer (Smart Type)

Features:

This equipment is used as a buffer between SMT machines, avoiding plug boards due to speed.

1. Independent innovation patent design (patent: 2017 SR477350), No.1 in the industry initiative, can increase production capacity by 12.5 % per day.
2. Using Panasonic PLC programmable control system, touch screen operation, easy to understand.
3. There is Bluetooth WiFi installed in the machine, which can realize the APP remote control machine station
4. PLC has network interface, and can interface with MES system.
5. The lifting platform adopts imported screw, smooth, stable and wearproof.
6. Have a variety of working patterns: first in first out, last in first out, etc.
7. Stepping motor for transmission, stable and easy to use.
8. Unique modular structure design, tricolor warning light indicating work
9. Automatic fault detection, touch screen display failure IO point function, simple and clear.
10. Using Panasonic SENSOR, position the boards accurately and steadily.
11. Full automatic width adjustment design, imported ball screw, sliding rail and stepping motor, smooth, stable and accurate.
12. Variable transmission adjustment, easy to use.
13. SMEMA interface.

Technical Parameters:

1. Transmission height: 900 ± 30mm
2. Capacity of PCB storage: 20 PCS
3. Intersection: 17mm (or customer specified)
4. Belt Type: Imported wearproof flat belt
5. Transmission direction: From left to right or from right to left
6. Power supply: 230V AC; Single phase maximum 250 Volt

Options:

1. Capacity of PCB storage
2. Machine size
3. Cooling function
4. Other can be customized

Model	PCB Size (L x W ; mm)	Magazine Dimensions (L x W x H ; mm)	Machine Weight (Kg)
MT-250MW	50*50 – 450*250mm	500*760*1850mm	130
MT-300MW	50*50 – 450*300mm	500*800*1850mm	150
MT-400MW	50*50 – 450*400mm	500*900*1850mm	180

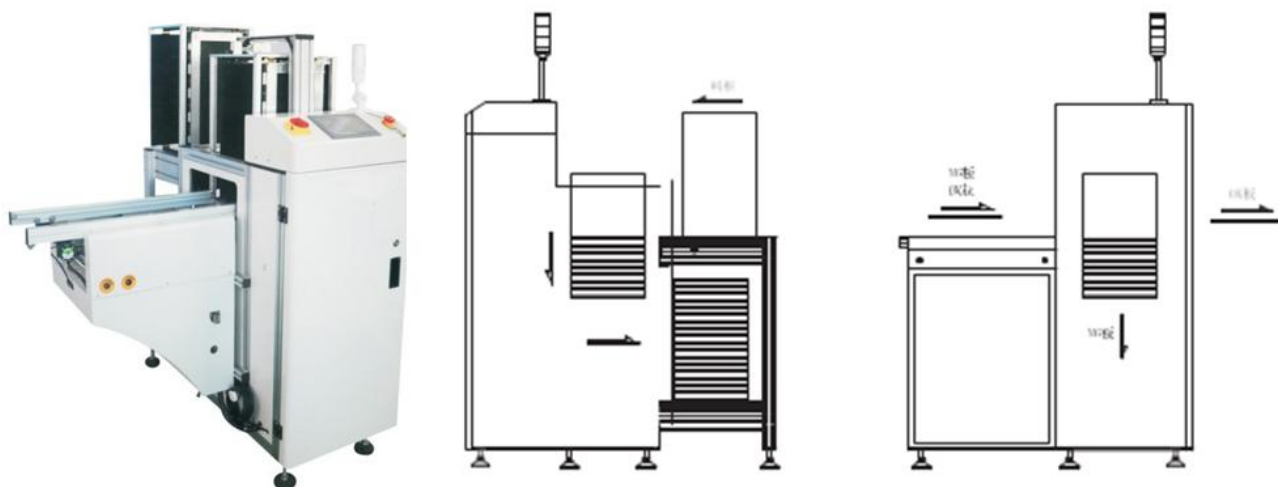

NG Buffer

Features:

This device is used for automatically separating and collecting NG boards from all boards after testing equipment.

1. Adopt Panasonic PLC programmable control system, touch screen operation, easy to understand.
2. Unique modular structure design, tricolor warning light indicating work.
3. Multiple points clamping design to ensure the homogeneity of each change frame.
4. Have a variety of working modes: NG board buffer, OK board temporary storage or directly go to the next machine.
5. There are two sets of storage cylinder and direct cylinder, Japanese SMC cylinder, stable and reliable.
6. Automatic fault detection, touch screen display failure IO point function, simple and clear.
7. The transmission is driven by a stepping motor, accurate and stable.
8. Use imported wire bar platform, smooth, stable and wearproof.
9. Adopt German screw, resistant to folding and wear.
10. Compatible SMEMA interface.

Technical Parameters:

1. Transmission height: 900 ± 30mm
2. Indexing pitch: 10.20.30.40 mm or customer specified
3. Numbers of magazine: upper 1; bottom 1
4. Magazine replacement time: about 30 seconds or customer specified
5. Belt Type: Imported wearproof flat belt
6. Track fixed mode: front fixed or customer specified
7. Transmission direction: From left to right or from right to left
8. Power : 230V AC; Single phase maximum 250 Volt
9. Air pressure and consumption: 4-6 bar, up to 10 litres per minute

Options:

1. Capacity of magazine
2. Safety protection
3. Automatic width adjustment function
4. Other can be customized

Models	PCB Size (L x W ; mm)	Magazine Size (L x W x H ; mm)	Magazine Dimensions (L x W x H ; mm)	Machine Weight (Kg)
MT-250LM	50*50 - 330*250mm	355*320*563mm	1200*1200*1600mm	150
MT-330LM	50*50 - 445*330mm	460*400*563mm	1450*1300*1600mm	180
MT-390LM	50*50 - 530*390mm	535*460*563mm	1600*1500*1600mm	210
MT-460LM	50*50 - 530*460mm	535*530*563mm	1600*1600*1600mm	240

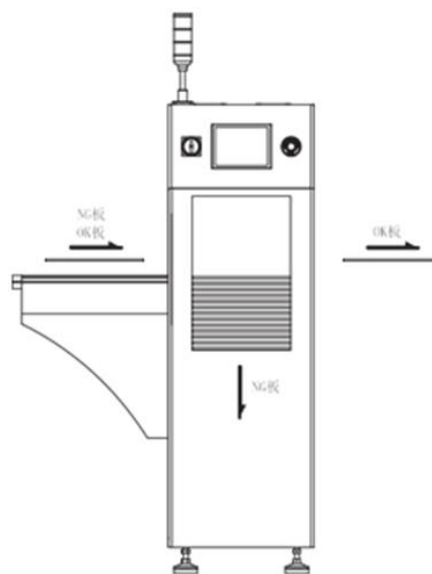

Multi-Functional Buffer

Features:

This device is used as a buffer between SMT machines, avoiding plug boards due to speed.

1. Panasonic PLC programmable control system, touch screen operation, easy to understand.
2. A variety of working patterns: first in first out, last in first out, etc.
3. Have fully automatic width adjustment function.
4. The width of the rail can be adjusted by ball screw+ sliding track, smooth and precise.
5. The transmission is driven by step motor, accurate and stable.
6. Use imported screw platform, smooth, stable and wearproof.
7. SMEMA interface.

Technical Parameters:

1. Transmission height: 900 ± 30mm
2. Capacity of PCB storage: 20 PCS
3. Intersection: 17mm(or customer specified)
4. Belt Type: Imported wearproof flat belt
5. Transmission direction: From left to right or from right to left
6. Power: 230V AC; Single phase maximum 250 Volt

Options:

1. Capacity of PCB storage
2. Machine size
3. Cooling function
4. Other can be customized

Model	PCB Size (L x W ; mm)	Magazine Dimensions (L x W x H ; mm)	Machine Weight (Kg)
MT-250MC	50*50 – 450*250mm	500*760*1600mm	120
MT-300MC	50*50 – 450*300mm	500*800*1600mm	140
MT-400MC	50*50 – 450*400mm	500*900*1600mm	170



Conveyor

Features:

This device is used for transmission and detection in SMT production line.

1. Self-developed control system, stable and reliable.
2. Stepping motor for transmission, stable and easy to use.
3. Internal weight design to improve machine stability.
4. Special custom SENSOR, accurate and stable.
5. Use imported ball screw to adjust width, smooth and durable.
6. Variable transmission adjustment, convenient and easy to operate.
7. Compatible SMEMA interface.

Technical Parameters:

1. Transmission height: 900 ± 30 mm
2. Transmission speed: 0.5 to 20M/MIN
3. Belt type: imported wearproof flat belt
4. Transmission direction: From left to right or from right to left
5. Power : 230V AC; Single phase maximum 250 Volt
6. Track fixed mode: monorail: 1 track fixed. Double track: 1 track fixed, 2, 3, 4 tracks adjustable

Options:

1. Lighting system
2. Stop position
3. Length of machine
4. Dust-proof function
5. Others can be customized

	Model	PCB Size (L x W ; mm)	Magazine Dimensions (L x W x H ; mm)	Machine Weight (Kg)
Monorail	MT-050BC	50*50 – 400*350mm	500*680*900mm	55
	MT-080BC	50*50 – 600*350mm	800*680*900mm	75
	MT-100BC	50*50 – 800*350mm	1000*680*900mm	90
	MT-150BC	50*50 – 1300*350mm	1500*680*900mm	120
Double Track	MT-050DC	50*50 – 400*350mm*2	500*1170*900mm	80
	MT-080DC	50*50 – 600*350mm*2	800*1170*900mm	110
	MT-100DC	50*50 – 800*350mm*2	1000*1170*900mm	130
	MT-150DC	50*50 – 1300*350*2	1500*1170*900mm	170

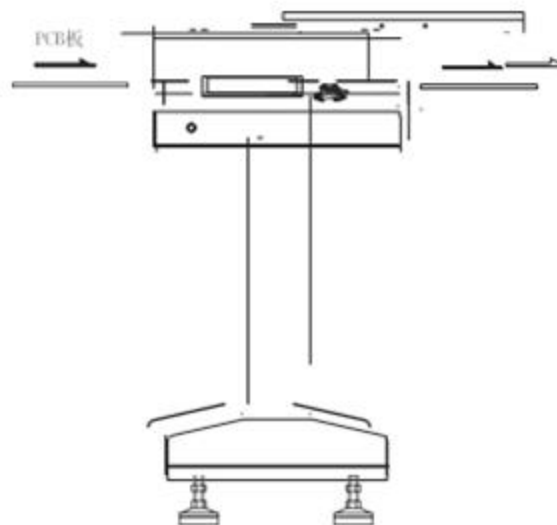

Conveyor (Smart Type)

Features:

This device is used for transporting PCBs.

1. Independent innovation patent design(patent: 2017 SR472155), No.1 in the industry, can increase production capacity by 12.5 % per day.
2. Adopt Panasonic PLC programmable control system, touch screen operation, easy to understand.
3. There is Bluetooth WiFi installed in the machine, which can achieve APP remote control machine station
4. PLC has network interface, which can interface with MES system.
5. Stepping motor for transmission, stable and easy to use.
6. Unique modular structure design, tricolor warning light indicating work
7. Automatic fault detection, touch screen display failure IO point function, simple and clear.
8. Using Panasonic SENSOR, position the PCBs accurately and steadily.
9. Full automatic width adjustment design, imported ball screw + stepping motor, smooth, stable and accurate.
10. Variable transmission adjustment, prompt and convenient.
11. Protective cover with switch to alarm and stop if behave wrongly.
12. Compatible SMEMA interface

Technical Parameters:

1. Transmission height: 900 ± 30mm
2. Transmission speed: 0.5 to 20M/MIN
3. Belt type: imported wearproof flat belt
4. Transmission direction: From left to right or from right to left
5. Power supply: 230V AC; Single phase maximum 250 Volt
6. Track fixed mode: monorail: 1 track fixed. Dual track: 1 track fixed, 2, 3, 4 tracks adjustable

Options:

1. Lighting system
2. Stop position
3. Length of machine
4. Others can be customize

	Model	PCB Size (L x W ; mm)	Magazine Dimensions (L x W x H ; mm)	Machine Weight (Kg)
Single Track	MT-050BW	50*50 – 400*350mm	500*670*1600mm	55
	MT-080BW	50*50 – 600*350mm	800*670*1600mm	75
	MT-100BW	50*50 – 800*350mm	1000*670*1600mm	90
Dual Track	MT-050DW	50*50 – 400*300mm *2	500*1100*1600mm	80
	MT-080DW	50*50 – 600*300mm *2	800*1100*1600mm	110
	MT-100DW	50*50 – 800*300mm *2	1000*1100*1600mm	130

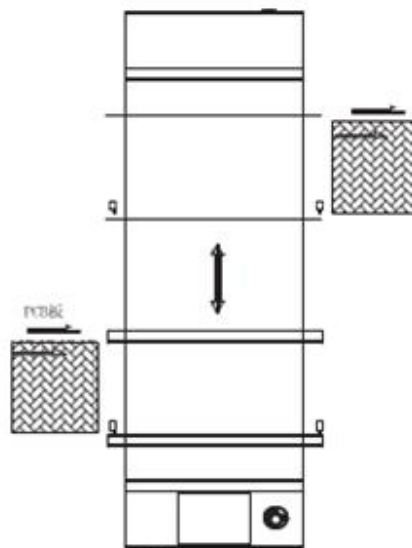

Automatic Translational Conveyor

Features:

This device is used for adjusting the width of transmission path of the production line.

1. Independent innovation patent design(patent: 2017 SR473988), No.1 in the industry, can increase production capacity by 12.5 % per day.
2. Adopt Panasonic PLC programmable control system, touch screen operation, easy to understand.
3. There is Bluetooth WiFi installed in the machine, which can achieve APP remote control machine station
4. PLC has network interface, which can interface with MES system.
5. The trolley is driven by step motor, stable and accurate.
6. Adopt stepping motor to transmiss, steady and stable, easy to use.
7. Unique modular structure design, tricolor warning light indicating working states.
8. Automatic fault detection, failure IO point displayed on the touch screen, simple and clear.
9. Adopt Panasonic SEMSOR for inlet, outlet and limit, accurate and stable.
10. Platform width can be adjusted automatically, adopting imported ball screw, sliding rail + stepping motor, accurate, smooth and stable.
11. Touch screen with a variety of working mode.
12. The whole machine adopts modular design, convenient to install and transport.
13. Specially designed trolley rails make the trolley move fast and smoothly.
14. Adopt German tow-chain cable, resistant to folding and wear.
15. Compatible SMEMA interface.

Technical Parameters:

1. Transmission height: 900 ± 30 mm
2. Transportation speed: 0.5-20M / min
3. Belt type: Imported wearproof flat belt.
4. Track fixed mode: front fixed or customer specified
5. Transmission direction: From left to right or from right to left
6. Power: 230V AC; Single phase maximum 250 Volt
7. Cycle time: ≥ 10 seconds

Options:

1. Number of cars
2. Length and width of the machine
3. Other can be customized to customer requirements

Model	PCB Size (L x W ; mm)	Magazine Dimensions (L x W x H ; mm)	Machine Weight (Kg)

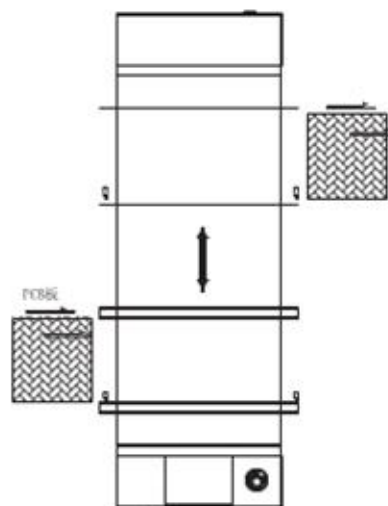

Automatic Translational Conveyor

Features:

This device is suitable for adjusting the width of the transmission path of the production line.

1. Adopt Panasonic PLC programmable control system, touch screen operation, easy to understand.
2. Unique modular structure design, tricolor warning light indicating work.
3. The vehicle is driven by stepper motor, stable and accurate.
4. Adopt Panasonic SENSOR for inlet, outlet and limit, accurate and stable.
5. Automatic fault detection, touch screen display failure IO point function, simple and clear.
6. Specially designed trolley rails make the trolley move fast and smoothly.
7. Touch screen with a variety of working mode.
8. Trolley width is adjusted by ball rod + sliding track, smooth and accurate.
9. Adopt German import tow-chain cable, resistant to folding and wear.
10. The whole machine adopts modular design, convenient to install and transport.
11. SMEMA interface.

Technical Parameters:

1. Transmission height: 900 ± 30mm
2. Transportation speed: 0.5-20M / min
3. Belt type: Imported wearproof, flat belt
4. Track fixed mode: front fixed or customer specified
5. Transmission direction: From left to right or from right to left
6. Power supply: 230V AC; Single phase maximum 250 Volt
7. Cycle time: ≥ 10 seconds

Options:

1. Number of trolleys
2. Length and width of the machine
3. Automatic width adjustment function
4. Other can be customized

Model	PCB Size (L x W ; mm)	Magazine Dimensions (L x W x H ; mm)	Machine Weight (Kg)

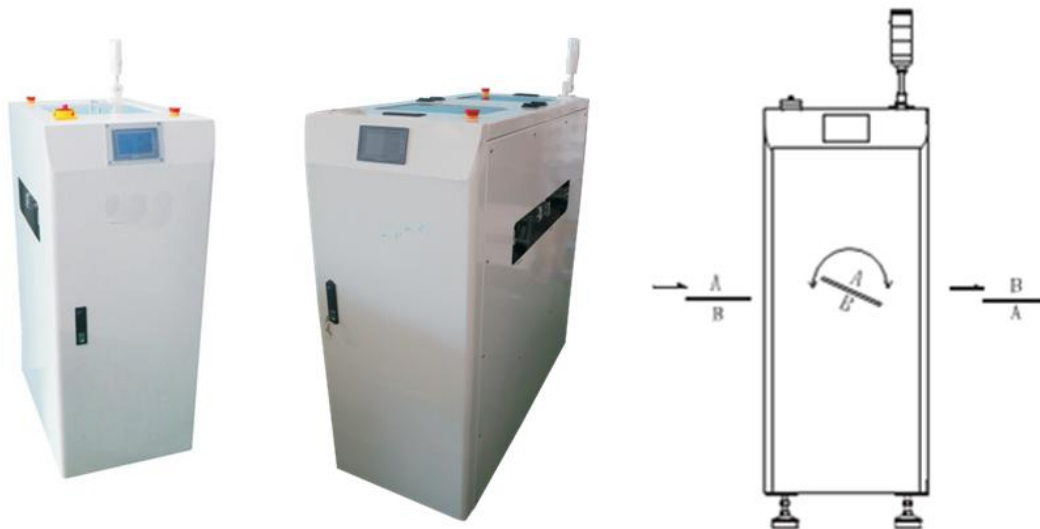

Automatic Inverting Machine

Features:

This equipment is designed for SMT unmanned workshop. It is used for double-sided PCB boards, which need to be inverted 108 degrees automatically.

1. Independent innovation patent design(patent: 2018 SR168472), No.1 in the industry, can increase production capacity by 12.5 % per day.
2. Adopt Panasonic PLC programmable control system, touch screen operation, easy to understand.
3. There is Bluetooth WiFi installed in the machine, which can achieve APP remote control machine station.
4. PLC has network interface, which can interface with MES system.
5. Adopt Stepping motor to invert, positioning fast, steadily and precisely.
6. Buffer deceleration design, smooth and accurate.
7. Unique modular structure design, tricolor warning light indicating working states.
8. Automatic fault detection, failure IO point shown in the touch screen , simple and clear.
9. Adopt Panasonic SEMSOR for inlet, outlet and limit, accurate and stable.
10. Adopt imported ball screw to adjust the width fully automatically, smooth, stable and accurate.
11. Equipped with photoelectric protection sensor, secure and reliable.
12. The transmission with double-layer structure is driven by stepping motor, smooth and stable.
13. Two-track transmission, independent overturn structure and independent control, stable and easy to operate
14. The whole machine adopts fully enclosed design, ensure the highest level of safety and protection.
15. Compatible SMEMA interface.

Technical Parameters:

1. Transmission height: 900 ± 30mm
2. PCB thickness: 0.6-4mm
3. Flip time: about 5 seconds
4. Belt Type: Imported wearproof flat belt
5. Transmission direction: From left to right or from right to left
6. Power supply: 230V AC; Single phase maximum 250 Volt

Options:

1. PCB thickness
2. Machine size
3. Inverting mode
4. Other can be customized

Model	PCB Size (L x W ; mm)	Machine Dimensions (L x W x H ; mm)	Machine Weight (Kg)
MT-250IM	50*50 – 450*250mm	500*680*1600mm	

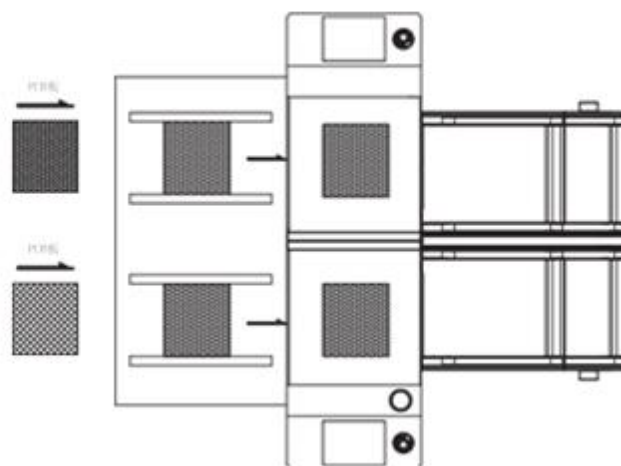

Automatic Unloader (Dual Track)

Features:

1. Panasonic PLC programmable control system, touch screen operation, simple and easy to understand.
2. Unique module structure design, three-color warning lamp indicating working states.
3. Multi-point clamping design to ensure the same repeatability of each frame change.
4. The unique design of the push plate structure, each track is equipped with a push rod, with stable and reliable performance, and prevent the boards from breaking.
5. Automatic fault detection and IO point display on the touch screen, simple and clear.
6. The lifting platform adopts imported screw, smooth, stable and wearproof.
7. PCB will be collected into the corresponding magazines in different tracks, and 50 pieces of boards can be stored in each magazine.
8. Adopt German towing cable, which is resistant to folding and wear.
9. SMEMA interface

Technical Parameters:

1. Transmission height: 900 ± 30 mm
2. Indexing pitch: 10.20.30.40 mm or customer specified
3. Amount of magazine: 1 for top ,1 for bottom
4. Magazine replacement time: about 30 seconds or customer specified
5. Track fixed mode: front fixed or customer specified
6. Transmission direction: From left to right or from right to left
7. Power supply: 230V AC; Single phase maximum 250 Volt
8. Air pressure and air consumption: 4-6 bar, up to 10 litres per minute

Options:

1. Capacity of magazine
2. All safety protection
3. Automatic width adjustment function
4. Other can be customized

Models	PCB Size (L x W ; mm)	Magazine Size (L x W x H ; mm)	Magazine Dimensions (L x W x H ; mm)	Machine Weight (Kg)
MT-250DUL	50*50 – 330*250mm	355*320*563mm	1750*1500*1600mm	280
MT-330DUL	50*50 – 445*330mm	460*400*563mm	2000*1600*1600mm	320
MT-390DUL	50*50 – 530*390mm	535*460*563mm	2200*1750*1600mm	360

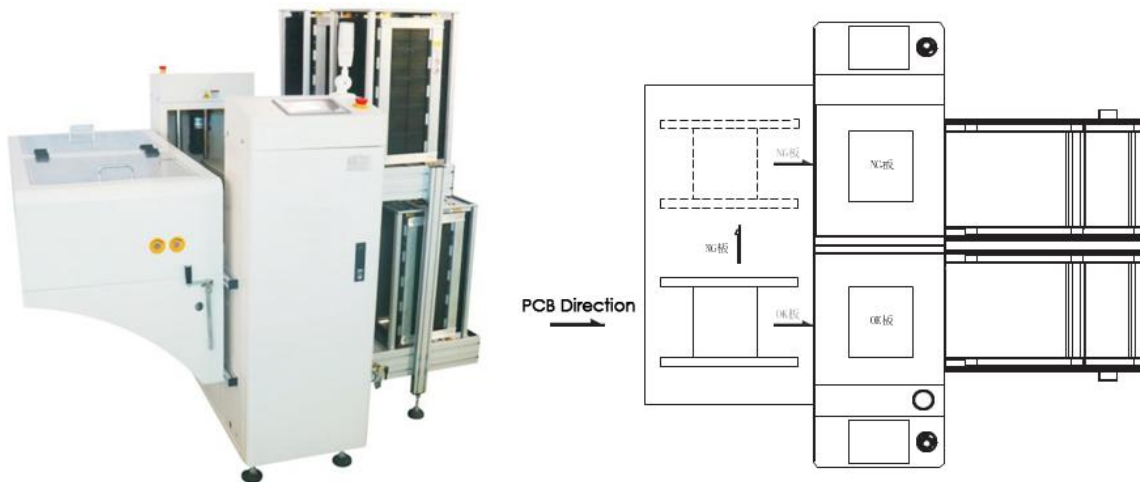

Unloader NG/OK

Features:

This machine is suitable for the separation of NG and OK PCB after AOI

1. Panasonic PLC programmable control system, touch screen operation, easy to understand.
2. Unique modular structure design, tricolor warning light indicating working states
3. Special signal processing method, distinguish the signal of NG/OK from the upper computer accurately and promptly.
4. Multi-point clamping design to ensure the homogeneity of each change frame.
5. Unique design of the push plate structure, to ensure the board not to be broken, stable and reliable.
6. With translation mechanism, separate NG or OK PCB boards and collect them into different magazine, each magazine stores 50 plates.
7. Automatic fault detection, touch screen display failure IO point function, simple and clear
8. Use imported wire bar platform, smooth, stable and wearproof.
9. Adopt German tow-chain cable, resistant to folding and wear.
10. SMEMA interface

Technical Parameters:

1. Transmission height: 900 ± 30 mm
2. Indexing pitch: 10.20.30.40 mm or customized
3. Numbers of magazine: 1 for top, 1 for bottom;
4. Magazine replacement time: about 30 seconds or customized
5. Track fixed mode: front fixed or customized
6. Transmission direction: From left to right or from right to left
7. Power: 230V AC; Single phase maximum 250 Volt
8. Air pressure and air consumption: 4-6 bar, up to 10 litres per minute

Options:

1. Number of magazine stored
2. All safety protection
3. Automatic width adjustment function
4. Other can be customized

Models	PCB Size (L x W ; mm)	Magazine Size (L x W x H ; mm)	Magazine Dimensions (L x W x H ; mm)	Machine Weight (Kg)
MT-250HW	50*50 – 330*250mm	355*320*563mm	1750*1500*1600mm	260
MT-330HW	50*50 – 445*330mm	460*400*563mm	2000*1600*1600mm	290
MT-390WH	50*50 – 530*390mm	535*460*563mm	2200*1750*1600mm	320
MT-460HW	50*50 – 530*460mm	535*530*563mm	2200*1900*1600mm	350

CONNECTING CONVEYOR CATALOG



Automatic Unloader (Dual Rail for NG and OK)

Features:

This equipment is suitable double rail AOI, receiving NG and OK boards by distinguishing them into different magazines.

1. Panasonic PLC programmable control system, touch screen operation, simple and easy to understand.
2. It is No. 1 in the industry to design dual rail unloader by separating NG and OK, space saving and efficiency.
3. Unique module structure design, three-color warning lamp instruction.
4. Each lifting platform is driven by Panasonic servo system, steady, stable and accurate.
5. Special signal processing method can accurately and promptly distinguish NG or OK signals and sent to the upper computer.
6. Multi-point clamping design to ensure the same repeatability of each frame change.
7. The unique design of the push plate structure, each rail is equipped with a push rod, with stable performance, reliable performance and no broken plate.
8. Upper and lower layer design, 10 pieces of NG boards can be stored on the upper layer, and 50 pieces of OK boards can be stored on the lower layer.
9. It has the function of automatic fault detection and IO point display on the touch screen, which is simple and clear.
10. The lifting platform adopts imported screw, smooth, stable and wearproof.
11. Adopt German towing cable, which is resistant to folding and wear.
12. SMEMA interface

Technical Parameters:

1. Transmission height: 900 ± 30mm
2. Indexing pitch: 10.20.30.40 mm or customer specified
3. Amount of magazine: 1 for top, 1 for bottom
4. Magazine replacement time: about 30 seconds or customer specified
5. Track fixed mode: front fixed or customer specified
6. Transmission direction: From left to right or from right to left
7. Power supply: 230V AC; Single phase maximum 250 Volt
8. Air pressure and air consumption: 4-6 bar, up to 10 litres per minute

Options:

1. Capacity of magazine
2. All safety protection
3. Automatic width adjustment function
4. Other can be customized

Models	PCB Size (L x W ; mm)	Magazine Size (L x W x H ; mm)	Magazine Dimensions (L x W x H ; mm)	Machine Weight (Kg)
MT-250DM	50*50 – 330*250mm	355*320*170mm	1350*1450*1600mm	260
MT-330DM	50*50 – 445*330mm	460*400*170mm	1600*1650*1600mm	290
MT-390DM	50*50 – 530*390mm	535*460*170mm	1900*1750*1600mm	320
MT-460DM	50*50 – 530*460mm	535*530*170mm	1900*1900*1600mm	360

CONNECTING CONVEYOR CATALOG

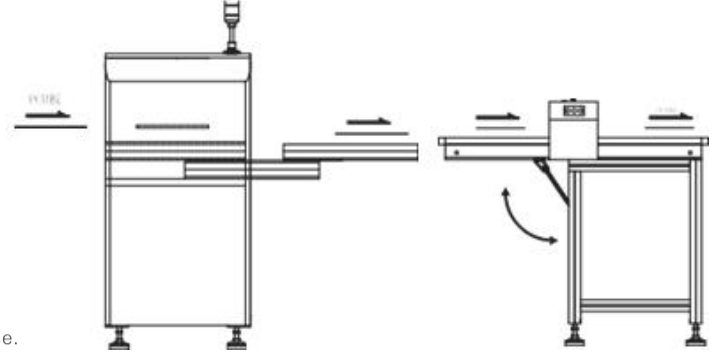

Automatic Aisle Conveyor

Features:

1. This equipment is suitable for channel production lines .
2. Adopt PLC programmable control system, stable and reliable.
3. Step motor is adopted for transmission, with stable performance and convenient use.
4. Internal weight design to improve the stability of the machine.
5. Adopt special customized SENSOR , accurate and stable.
6. Adopt imported ball screw to widen, smooth and durable.
7. Fully enclosed design and safety protection switch , ensure the safety of operation .
8. Variable transmission speed, convenient and effective.
9. Compatible SMEMA interface.

Technical Parameters:

1. Transmission height :900 + 30mm
2. Transmission speed: 0.5-20m /MIN
3. Belt type: imported wearproof flat belt
4. Transmission direction: from left to right or from right to left is optional
5. Power supply :230V ac; Single phase maximum 250 volts
6. Track fixed mode: front fixation or customer specified
7. Cycle time: About 15 s
8. Aisle width :800mm or customer specified technical parameters:

Options:

1. Lighting system
2. Stopper
3. Machine dimensions
4. Other can be customized

Models	PCB Size (L x W ; mm)	Magazine Size (L x W x H ; mm)	Magazine Dimensions (L x W x H ; mm)	Machine Weight (Kg)
Lifting Gate Conveyor	MT-050BC	50*50 – 460*350mm	1500*610*1000mm	130
Automatic Aisle Conveyor	MT-050DC	50*50 – 460*8350mm	1500*610*1000mm	150